



Life's messy. Clean it up.®

# User's Guide

## 16981 Series

- Assembly
- Operation
- Safety
- Storage

*Thanks for buying a POWERSTEAMER® PROHEAT™ PLUS Heated Solution Deep Cleaner.*

We're glad you purchased a BISSELL POWERSTEAMER® PROHEAT™ PLUS Heated Formula Deep Cleaner. Everything we know about floor care went into the design and construction of this complete, high-tech home cleaning system.

Your POWERSTEAMER® PROHEAT™ PLUS is well made, and we back it with a full one-year warranty. We also stand behind it with a knowledgeable, dedicated Consumer Services department, so, should you ever have a problem, you'll receive fast, considerate assistance.

My great-grandfather invented the floor sweeper in 1876. Today, BISSELL is a global leader in the design, manufacture, and service of high quality homecare products like your POWERSTEAMER® PROHEAT™ PLUS.

Thanks again, from  
all of us at BISSELL.

Mark J. Bissell  
President and Chief Executive Officer

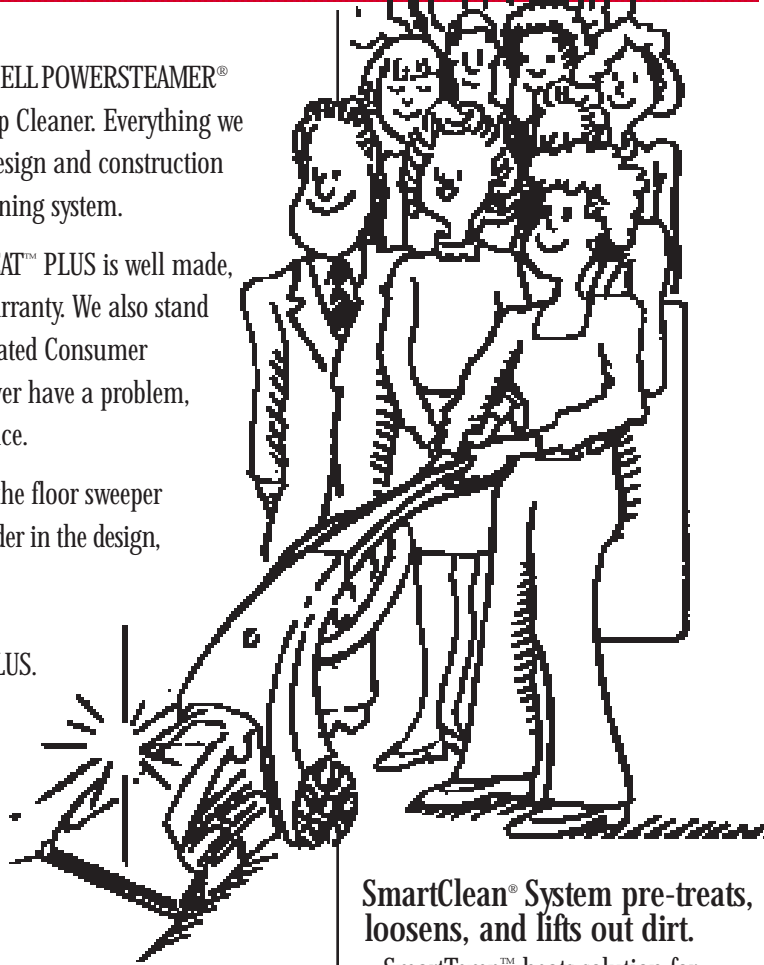

**SmartClean® System pre-treats, loosens, and lifts out dirt.**

- SmartTemp™ heats solution for best cleaning
- On-board DirtLifter® TurboBrush™
- DirtLifter® PowerBrush lifts deep down dirt, grooms carpet
- SmartMix® auto-adjusts formula for every cleaning job
- Tank-in-Tank™ is easy to use - saves trips to empty and refill
- ReadyTools™ instantly converts from floor cleaning to tools

# IMPORTANT SAFETY INSTRUCTIONS

**WARNING:** When using an electrical appliance, basic precautions should be observed, including the following: Read all instructions before using your POWERSTEAMER® PROHEAT™ PLUS. To reduce the risk of fire, electric shock, or injury, use indoors only. Do not immerse. Use only on surfaces moistened by cleaning process. Always connect to a properly grounded outlet. Unplug from outlet when not in use and before conducting maintenance or troubleshooting.

- Do not leave machine when it is plugged in
- Do not service machine when it is plugged in
- Do not use with damaged cord or plug
- Do not use machine if it has been dropped, damaged, left outdoors or dropped into water
- Do not expose to rain, store indoors
- Do not handle unit with wet hands
- Do not pull or carry by cord, use cord as a handle, close door on cord, pull cord around sharp corners or edges, run appliance over cord, or expose cord to heated surfaces
- Do not carry the appliance while in use
- Do not unplug by pulling on cord-unplug by grasping plug
- Do not handle plug or appliance with wet hands
- Do not put any object into appliance openings, use with blocked opening, or restrict air flow
- Do not expose hair, loose clothing, fingers or body parts to openings or moving parts
- Do not pick up hot or burning objects
- Do not pick up flammable or combustible materials (lighter fluid, gasoline, kerosene, etc.) or use in the presence of explosive liquids or vapor
- Do not use appliance in an enclosed space filled with vapors given off by oil base paint, paint thinner, some moth proofing substances, flammable dust, or other explosive or toxic vapors
- Do not pick up toxic material (chlorine bleach, ammonia, drain cleaner, gasoline, etc.)
- Do not modify the 3-prong grounded plug
- Do not allow to be used as a toy
- Do not use for any purpose other than described in this User's Guide
- Use only manufacturer's recommended attachments
- Use only cleaning products formulated by BISSELL for use in this appliance

- Keep openings free of dust, lint, hair, etc.
- Use only commercially available floor cleaners and waxes intended for machine application
- Keep appliance on a level surface
- Turn off all controls before unplugging
- Unplug by grasping the plug, not the cord
- Unplug before attaching the TurboBrush™
- Be extra careful when cleaning stairs
- Pay close attention when working around children

## SAVE THESE INSTRUCTIONS.

THIS MODEL IS FOR HOUSEHOLD USE ONLY.

Commercial use of this unit voids the manufacturer's warranty.

## GROUNDING INSTRUCTIONS

This appliance must be connected to a grounded wiring system. If it should malfunction or break down, grounding provides a safe path of least resistance for electrical current, reducing the risk of electrical shock. The cord for this appliance has an equipment-grounding conductor and a grounding plug. It must only be plugged into an outlet that is properly installed and grounded in accordance with all local codes and ordinances.

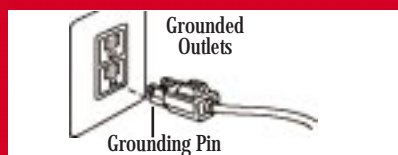

**WARNING:** Improper connection of the equipment-grounding conductor can result in a risk of electrical shock. Check with a qualified electrician or service person if you aren't sure if the outlet is properly grounded. **DO NOT MODIFY THE PLUG.** If it will not fit the outlet, have a proper outlet installed by a qualified electrician. This appliance is designed for use on a nominal 120-volt circuit, and has a grounding attachment plug that looks like the plug in the drawing above. Make certain that the appliance is connected to an outlet having the same configuration as the plug. No plug adapter should be used with this appliance.

**⚠ CAUTION:**  
**POWERSTEAMER®**  
**PROHEAT™ PLUS**  
 uses water and  
 must not be  
 stored where  
 there is danger  
 of freezing.  
 Freezing will  
 damage internal  
 components.

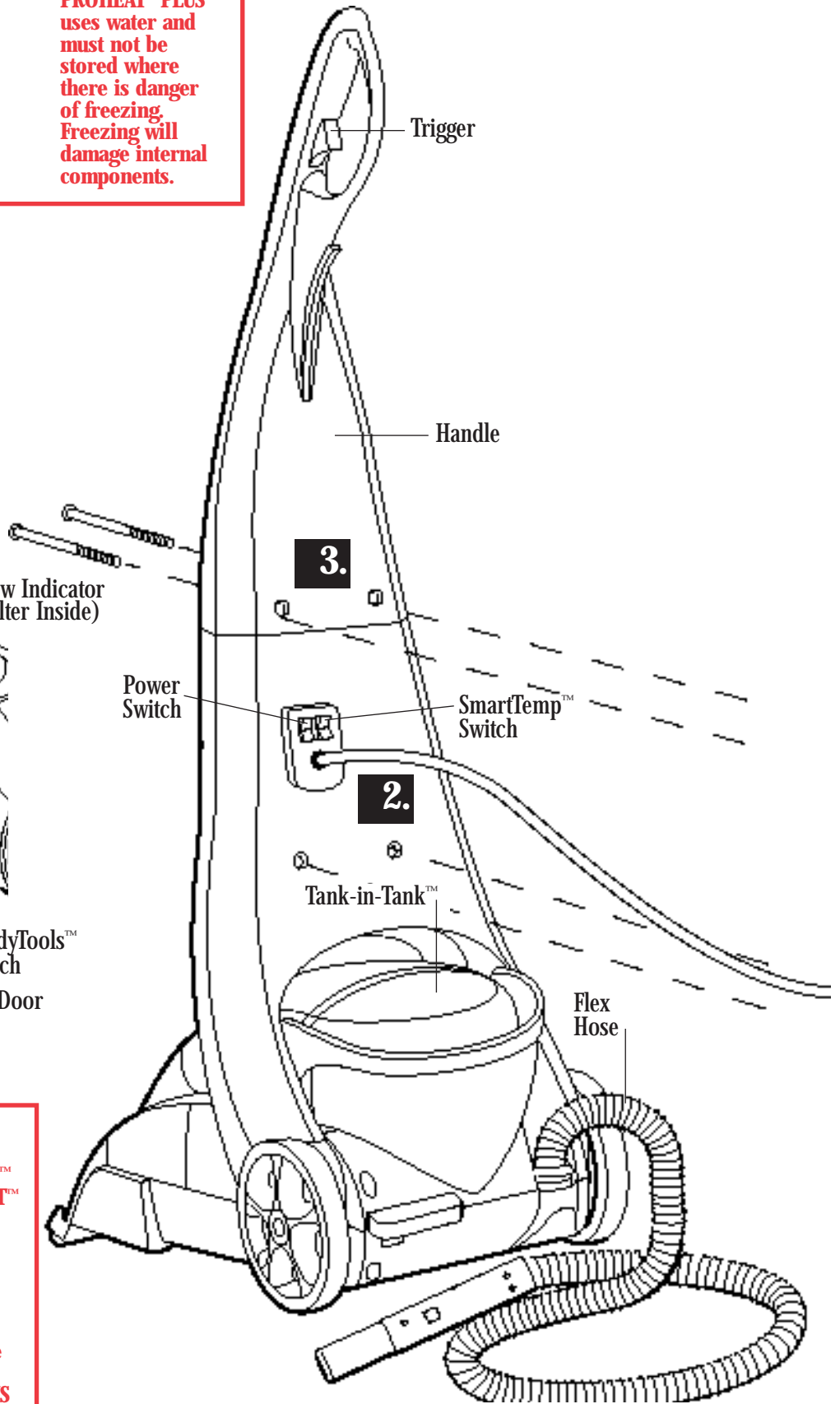
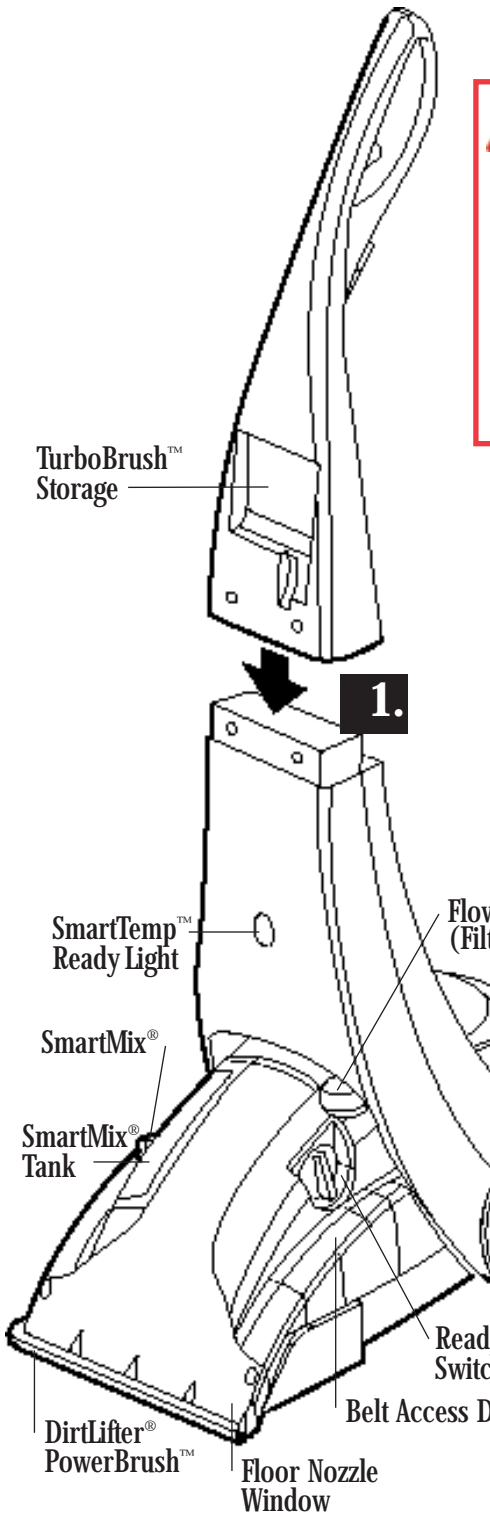

**⚠ WARNING:** Use only **BISSELL Fiber Cleansing Formula™** in your **POWERSTEAMER® PROHEAT™ PLUS**. Use of cleaning formulas which contain lemon or pine oil may damage this appliance and void warranty. Chemical spot cleaners or solvent-based soil removers should not be used. These products may react with the plastic materials used in your **POWERSTEAMER® PROHEAT™ PLUS** causing cracking or pitting.

# Putting it together

1. Slide upper handle onto lower handle.
2. Feed bundled power cord through tool caddy from caddy's flat side.
3. Align handle holes and tool caddy holes.
4. Place hex nut into back of tool caddy and hold in place. Insert bolt from front to back turning into hex nut until snug. Do not overtighten. Repeat steps 3 and 4 for second bolt and hex nut.

The only thing you will need to assemble your cleaner is a Phillips head  screwdriver.

5. Insert 2 screws into lower tube. Turn until snug. 
6. Snap tools into storage on the tool caddy.
7. Wrap power cord and flex hose as shown.

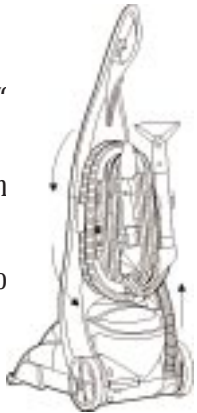

## What comes with your POWERSTEAMER® PROHEAT™ PLUS:\*

\*All parts may not be included with your model. More Tools are available. To order replacement parts or tools please refer to page 17.

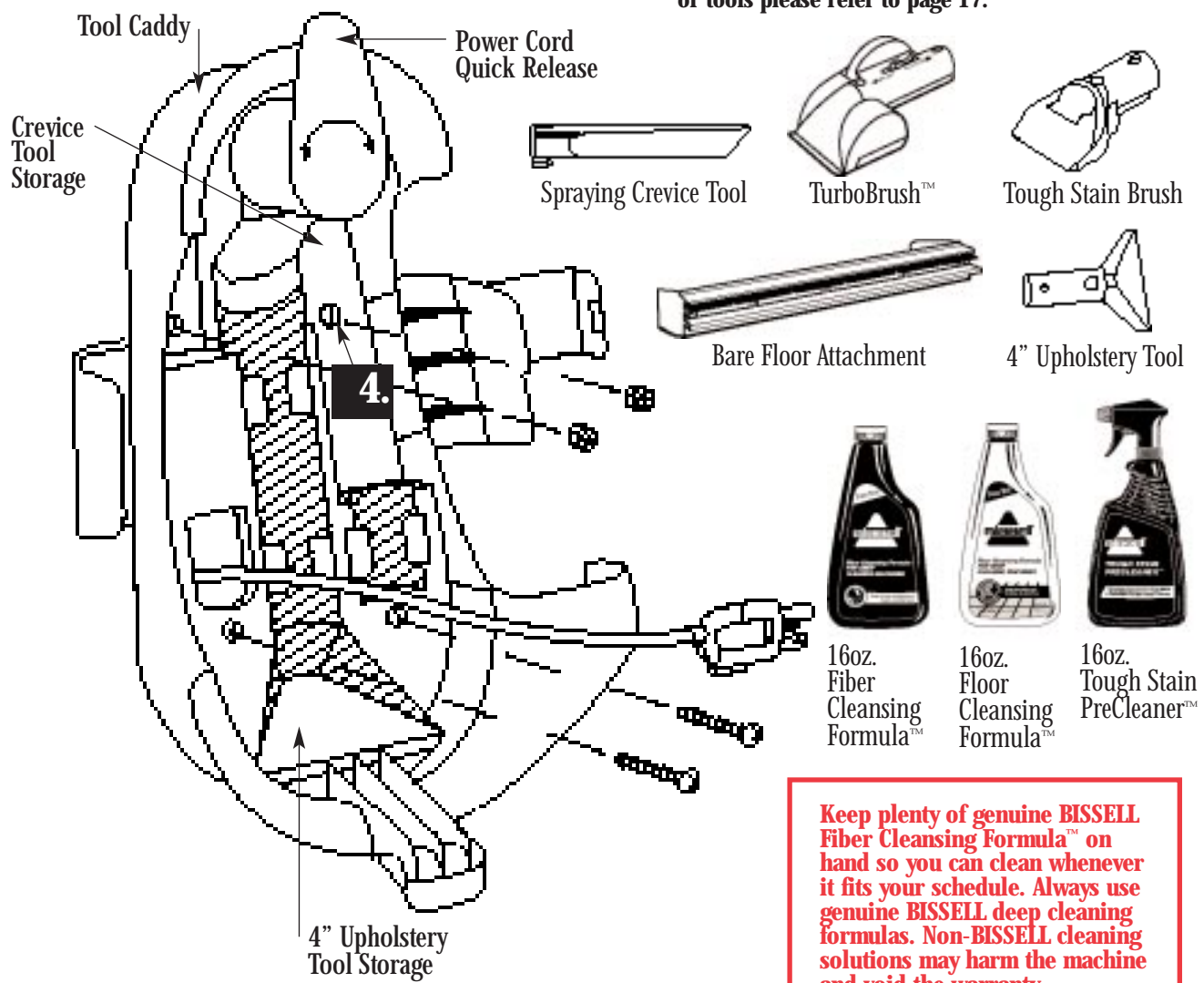

**Keep plenty of genuine BISSELL Fiber Cleansing Formula™ on hand so you can clean whenever it fits your schedule. Always use genuine BISSELL deep cleaning formulas. Non-BISSELL cleaning solutions may harm the machine and void the warranty.**



# The BISSELL SmartClean® System

POWERSTEAMER® PROHEAT™ PLUS is a home cleaning system that automatically mixes hot tap water with fiber cleansing formula and heats the cleaning solution as it is applied to the carpet. The combination of heated cleaning solution, powered brush and suction provide a safe and effective method of cleaning.

## The Basics: How it works

### SmartTemp™

Temperature control automatically heats the cleaning solution as it is being applied to the carpet (\*) to safely optimize cleaning effectiveness.

- The **SmartTemp™ Ready Light** indicates when the heater is ON and ready to clean. It is found on the front of the handle where it is easy to see while you clean.

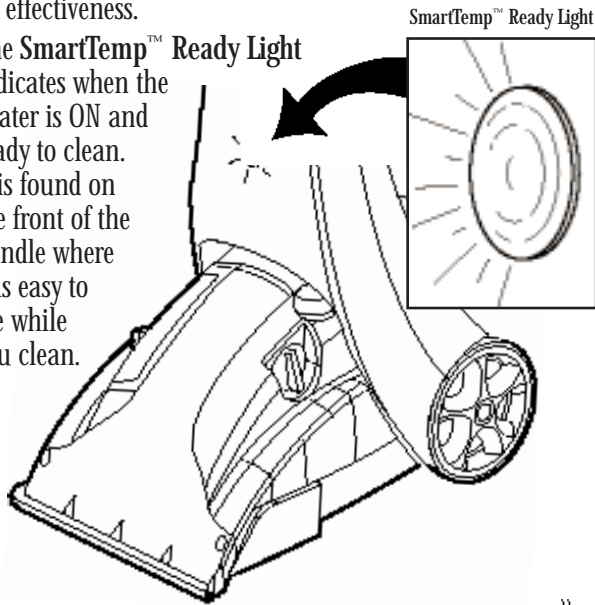

- The **Power Switch** controls power to the machine; both switches must be ON for SmartTemp™ to work.
- The **SmartTemp™ Switch** is found on the back of the handle next to the **Power Switch**. It illuminates in the ON position. You may choose not to use the SmartTemp™ feature if you are cleaning delicate wool, or oriental rugs.

*\* SmartTemp™ heats the cleaning solution for carpet and barefloor application only. It does not heat solution sprayed through the accessory tools.*

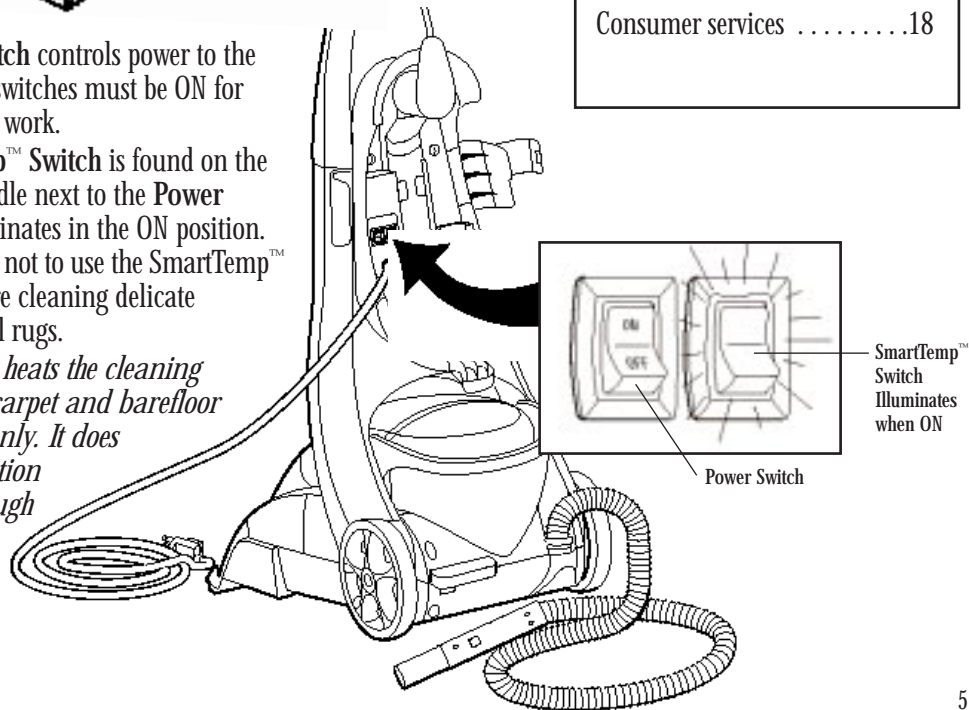

## Index

Safety instructions	2
Product view	3-4
Putting it together	4
What comes with your POWERSTEAMER® PROHEAT™ PLUS	4
The basics	5-9
Index	5
Cleaning carpets	10
Cleaning upholstery & small areas	11
Cleaning bare floors	12-13
Maintenance/ Putting it away	14
Troubleshooting	15-16
Parts	17
Warranty	18
Consumer services	18

## The Basics - continued

### SmartMix®

Provides custom control for each cleaning job.

1. Lift the SmartMix® concentrate bottle up out of the machine base.
2. Flip the bottle over so that the valve cap is in an upward position.
3. Unscrew the valve cap and fill the bottle to the mark with BISSELL Fiber Cleansing Formula.™
4. Replace the valve cap turning until snug.
5. Replace SmartMix® concentrate bottle.

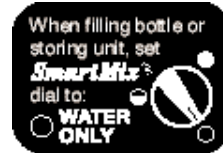
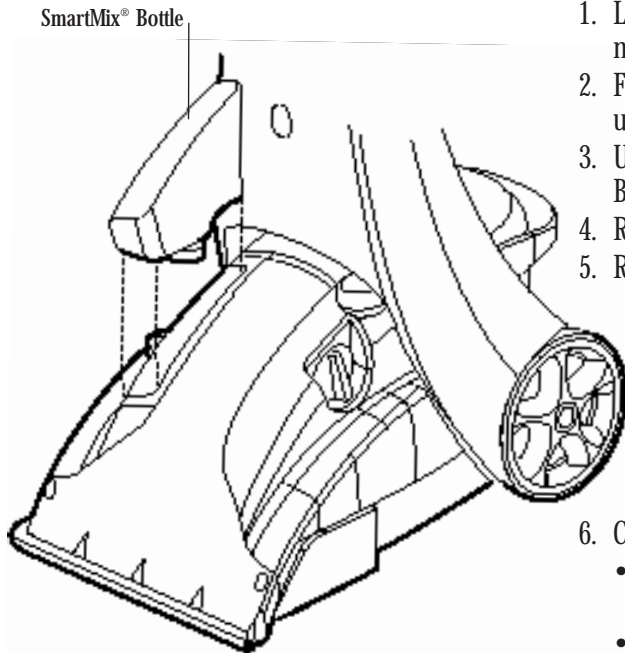

6. Choose the SmartMix® setting that fits the cleaning job.
  - **Water Only** – use for gentle cleaning or for the final rinse after cleaning.
  - **Normal** – automatically provides the best mix of water and concentrate for most cleaning jobs.
  - **High Traffic** – automatically mixes the right amounts of water and concentrate to dissolve tough grime and heavy soil.

### Tip:

Deep cleaning stairs and high traffic areas on a regular basis can prolong carpet life.

**WARNING:** Be extra careful when cleaning stairs.

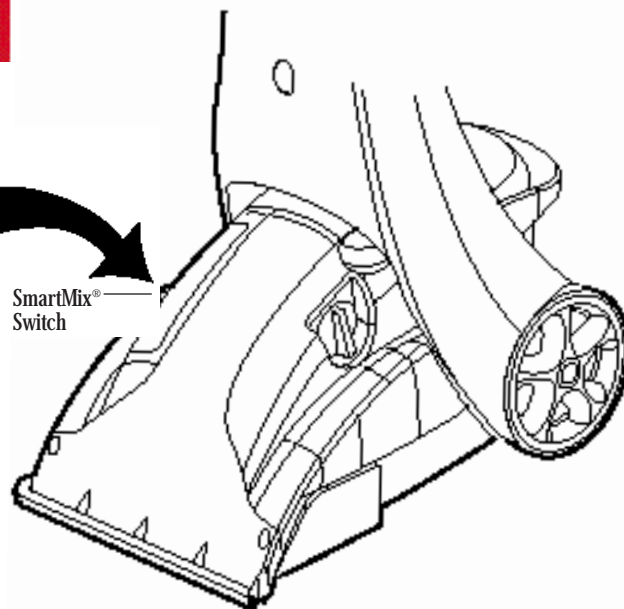
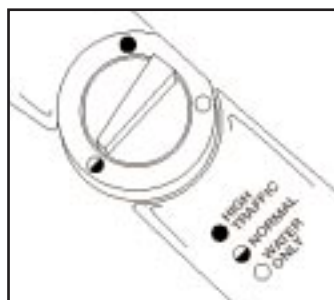

## DirtLifter® PowerBrush®

The powered brush roll at the floor nozzle is designed to enhance cleaning performance. The bristle pattern lifts out the deep down dirt while gently grooming carpet fibers. The floating suspension self-adjusts to all carpet heights and protects your carpet if you leave the power switch ON. When the machine handle is in the fully upright position, CarpetSaver™ automatically raises the brush off the carpet.

## Tank-in-Tank™ is easy to use

It is designed with a bladder inside for clean water. As you clean, the bladder will empty. Dirty water collects in the tank outside the bladder.

1. Step on handle release to lay the machine handle down out of the way.
2. Lift the Tank-in-Tank™ handle. The handle locks the lid in place.
3. Carry it like a bucket to fill at the sink.

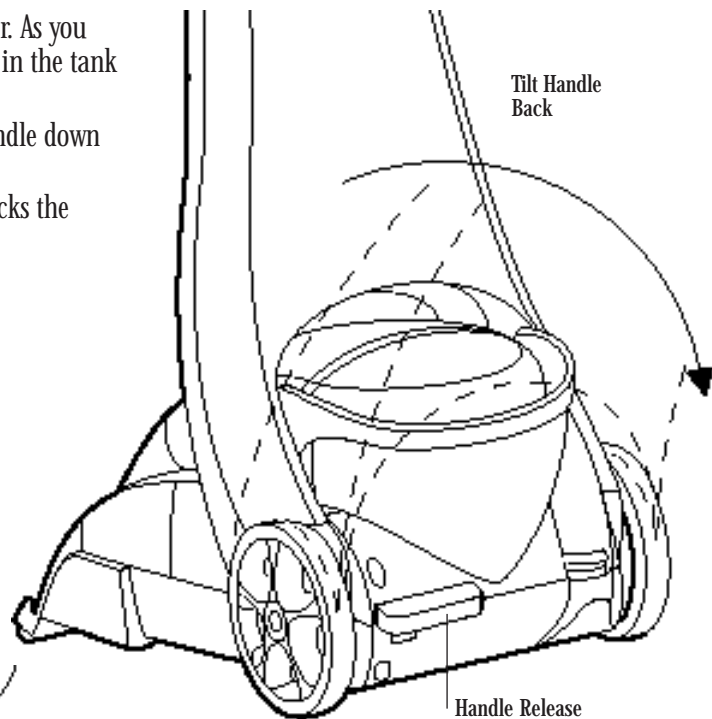
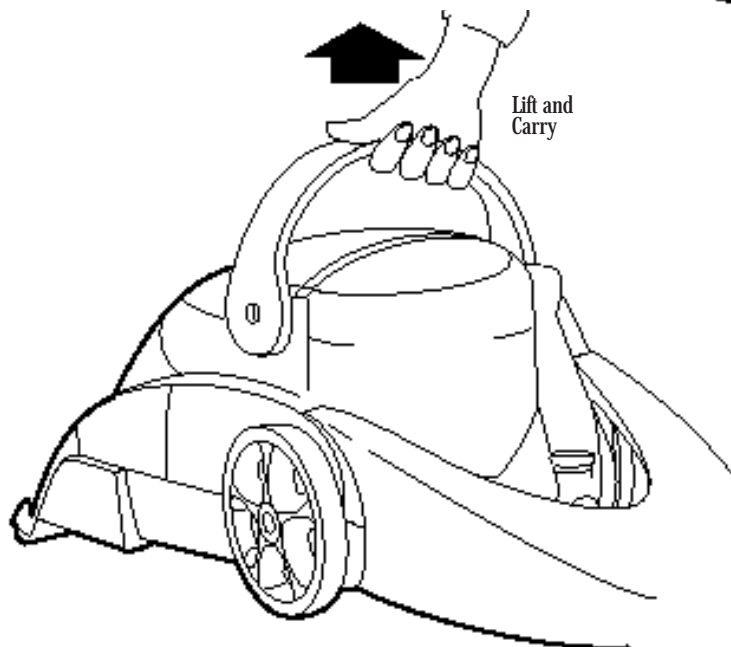

**WARNING:** Use only **BISSELL Fiber Cleansing Formula™** in your **POWERSTEAMER® PROHEAT™ PLUS**. Use of cleaning formulas which contain lemon or pine oil may damage this appliance and void warranty. Chemical spot cleaners or solvent-based soil removers should not be used. These products may react with the plastic materials used in your **POWERSTEAMER® PROHEAT™ PLUS**, causing cracking or pitting.

**NOTE:** Both the SmartMix® Bottle and the clean water tank must have liquid in them in order for the machine to spray. If one tank is empty the machine will not apply either cleaning solution or water only. If you're using the **WATER ONLY** setting, fill the SmartMix® Bottle with water also.

## The Basics - continued

Rotate Handle to Unlatch

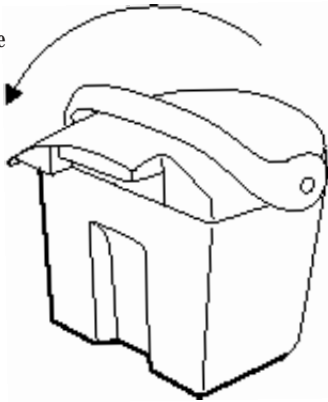

Fill Bladder only with clean tap water.

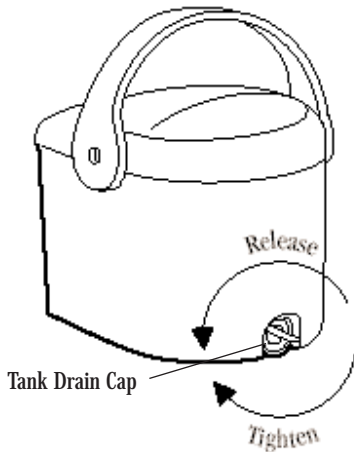
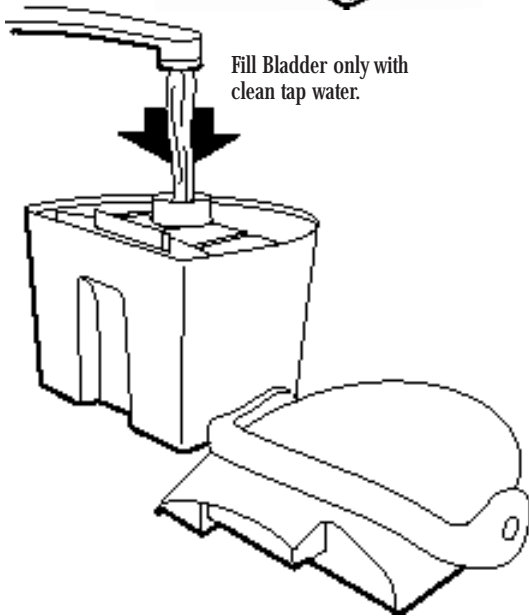

4. Set the tank down and rotate the handle forward to unlatch the lid. Lift off and set the lid aside.
5. Find the mouth of the bladder and fill to the bottom of the neck with **hot** tap water.  
**NOTE: Fill the Bladder with water only.**
6. Replace the tank lid matching the lid and tank edges. Handle must be in forward position to reinstall.
7. Rotate the handle to the carrying position to re-latch the lid.
8. Replace tank in machine base, seating firmly in place.
9. Rotate handle back down to the latched position.

### When it's time to empty the Tank-in-Tank™

10. Remove the Tank-in-Tank™ – follow steps 1 and 2 on page 7.
11. Carry the Tank-in-Tank™, like a bucket, to the sink where you will dispose of the dirty water.
12. Place in or at edge of sink, turn the Tank Drain Cap and remove to release the dirty water.
13. Replace Drain Cap.
14. Refill with clean tap water as above, steps 5 through 9, and refill the SmartMix® Bottle with BISSELL Cleansing Formula™ as necessary.
15. If the cleaning job is complete, rinse out the Tank-in-Tank™ by rinsing clean water between the bladder and tank.
16. Replace the Tank Drain Cap and return the Tank-in-Tank™ to the machine, following steps 6 through 9 above.
17. Refer to the **Putting it Away** section, page 14, for the final cleanup.

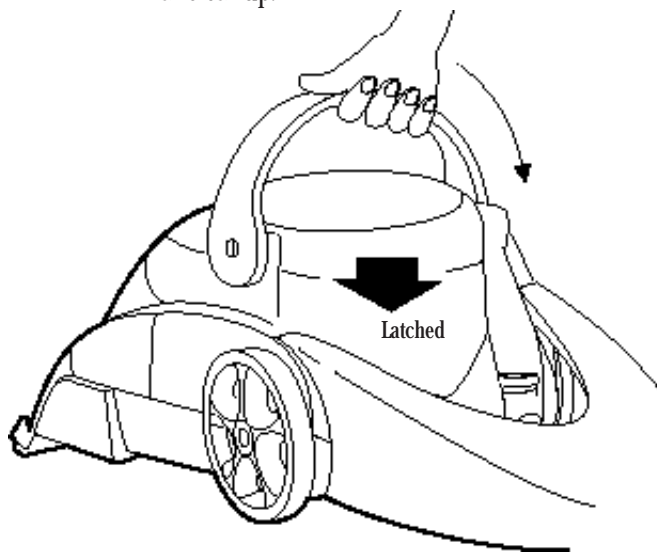
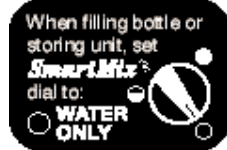



## The Flow Indicator

This is located on the machine base. It spins when the trigger is pressed to indicate that the machine is applying cleaning solution to the floor. It will stop spinning to indicate that the SmartMix® Bottle or bladder needs to be refilled, or when the trigger is released.

## ReadyTools™ Switch

This provides above floor cleaning with the flip of a switch. Just choose the cleaning tool, attach to the flex hose and POWERSTEAMER® PROHEAT™ PLUS is ready to clean upholstery and more.\*

\* Set the switch to **Floor Cleaning** when cleaning carpets or bare floors or set it to **Tools/PreTreat** when using the flex hose attachments or for pre-treating floors.

\* SmartTemp™ heats the cleaning solution for carpet and bare floor application only. It does not heat solution sprayed through the accessory tools.

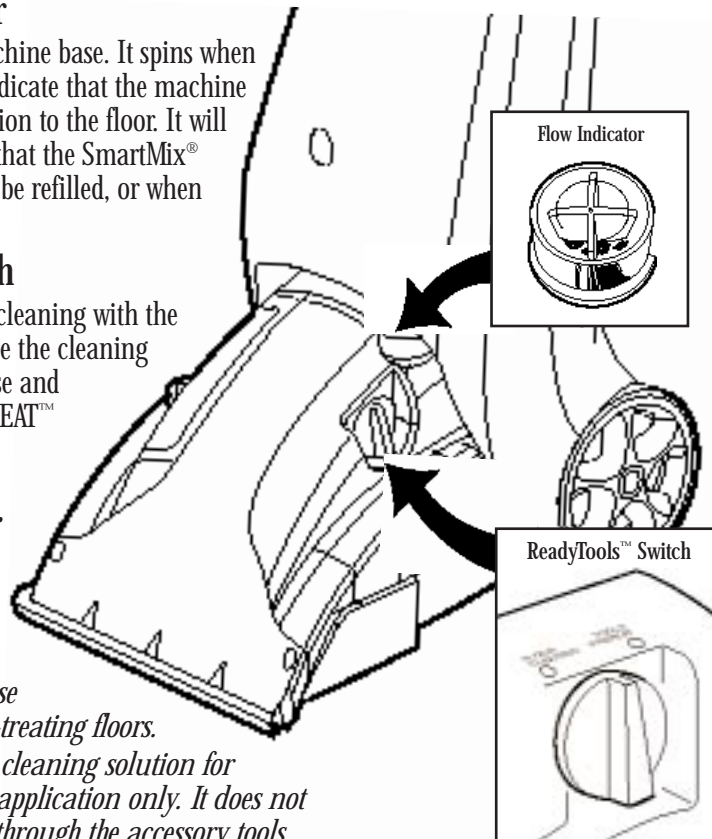

## How to use TurboBrush™ attachment

### Assembly

Unplug before attaching the TurboBrush™ Attach TurboBrush™ to the flex hose by pressing tool onto the grip/trigger until button snaps into hole. Make certain tool is secure

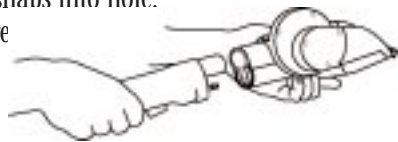

### Use

1. Move the TurboBrush™ switch to the "BRUSH" position. This activates the brush.
2. Place the tool directly on the soiled surface. Apply downward pressure on the tool and pull towards you while pulling trigger to spray cleaning solution.
3. Release the spray trigger and move the switch to the "SUCTION" position. Vacuum the area until no more cleaning solution can be removed.
4. Repeat steps 1-3 until no more dirt can be removed.



**Caution: Do not overwet.**

### When You're Done

1. Disconnect the TurboBrush™ from the vacuum flex hose by pushing down on the button lock and pulling straight off.
2. Once removed from the flex hose, the TurboBrush™ can be cleaned:
  1. Move the switch to the "SUCTION" position.
  2. Rinse under running water.
  3. Check spray nozzle for dirt. If necessary, clean with soft bristle brush.
4. Replace TurboBrush™ in its special storage location on the handle front.

# How to clean carpets

1. Plan activities to give carpet time to dry.
2. Remove easily moved furniture from the room (chairs, lamps, coffee tables, etc).
3. Vacuum thoroughly to pick up loose debris and pet hair before using the POWERSTEAMER® PROHEAT™ PLUS.
4. Plan your cleaning route to leave an exit path. It is best to begin cleaning in the corner farthest from your exit.

## Machine Preparation

5. Set up the machine following instructions in **The Basics** section, pages 5-9.
6. Use Fiber Cleansing Formula™ in the SmartMix® tank.
7. Choose the SmartMix® setting to match the cleaning job.
8. Set the ReadyTools™ switch on to either **Tools/PreTreat** or **Floor Cleaning**

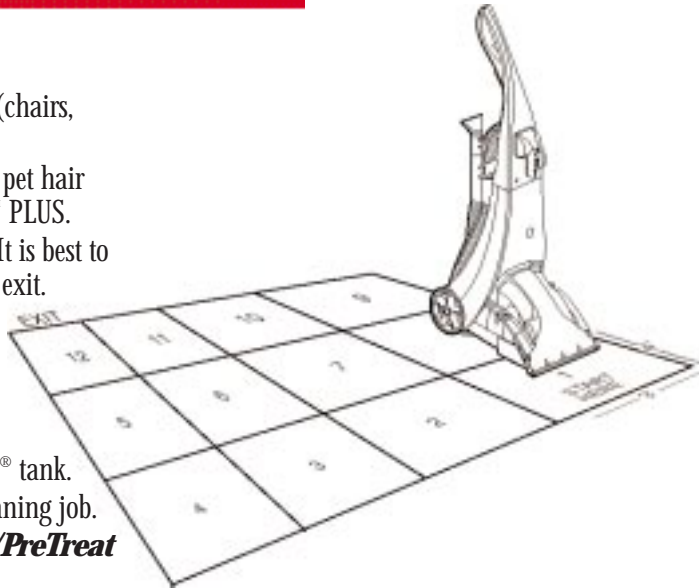

## Pre-Treating (Optional)

Improves cleaning effectiveness for heavily soiled carpet in high traffic areas such as entryways and hallways:

9. Set the SmartMix® dial to **High Traffic**.
10. Set the ReadyTools™ switch on **PreTreat**.
11. Plug into a proper outlet and turn ON both the Power and the SmartTemp™ switches.
12. While pressing the trigger, slowly make several passes over the area to be cleaned.  
**Caution: Do not overwet.**
13. Turn the machine Power switches OFF and let BISSELL Fiber Cleansing Formula™ dissolve the tough soil for 1-2 minutes before continuing.

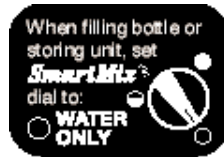

## Normal Cleaning

14. Plug into a proper outlet and turn the Power and the SmartTemp™ switches ON.
15. While pressing the trigger make one slow forward and back wet pass. Let the SmartTemp™ heated formula and DirtLifter® PowerBrush® do the work for you.  
**Caution: Do not overwet.**
16. Release the trigger and make one slow forward and back pass over the same area to remove any residual dirty water.

17. Repeat cleaning passes until solution being pulled up appears clean.
18. Continue passes without pressing the trigger until you can't see any more water being pulled up.

**NOTE: Both the SmartMix® and the clean water tank must have liquid in them in order for the machine to spray. If one tank is empty the machine will not apply either cleaning solution or water only.**

19. After cleaning, you may want to turn the SmartMix® to **Water Only** to give your carpeting a final rinse. This will insure thorough removal of embedded dirt loosened by the Fiber Cleansing Formula™.
20. When the cleaning job is complete refer to the **Maintenance/Putting it Away** section for machine cleanup and storage instructions, page 14.

# How to clean upholstery and small areas

## Important - Check Upholstery Tags:

1. Check manufacturer's tag before cleaning. "W" or "WS" on the tag means you can use your POWERSTEAMER® PROHEAT™ PLUS. If the tag is coded with "X" or "S" (with a diagonal strike through), or says "Dry Clean Only," do not proceed. Do not use on velvet or silk. If manufacturer's tag is missing or not coded, check with your furniture dealer.
2. Check for colorfastness in an inconspicuous place.
3. If possible, check upholstery stuffing. Colored stuffing may bleed through fabric when wet.
4. Plan activities to give upholstery time to dry.
5. Vacuum thoroughly to pick up loose debris and pet hair. Use a vacuum with a brush attachment and a crevice tool to clean in fabric folds and tufts.

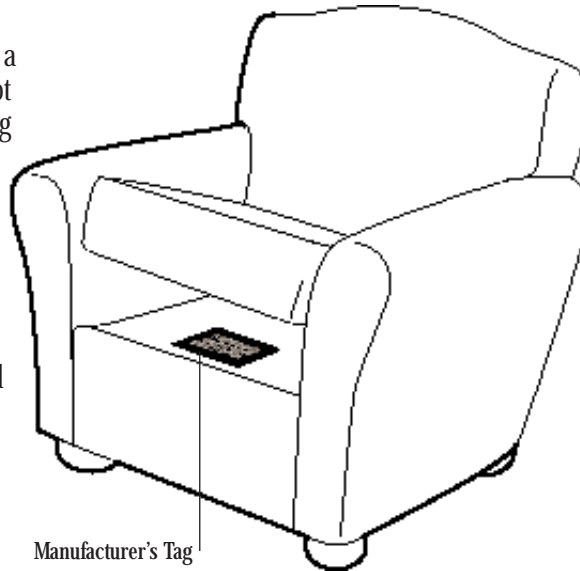

## Machine Preparation:

6. Set up the machine following instructions in *The Basics* section, pages 5-9.
7. Use Fiber Cleansing Formula™ in the SmartMix® tank.
8. Set the ReadyTools™ switch on **Tools and PreTreat**.  
*\* SmartTemp™ heats the cleaning solution for carpet and barefloor application only. It does not heat solution sprayed through the accessory tools.*
9. Set SmartMix® to **Normal**.

## Cleaning Technique

10. Choose the 4" Small Area Tool, the Tough Stain Brush, or the Spraying Crevice Tool and connect to the flex hose.

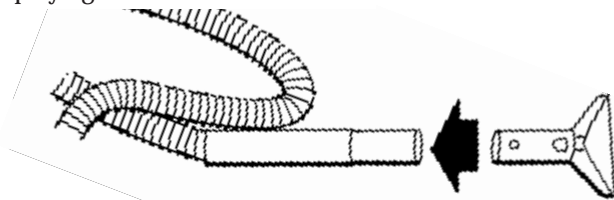

11. Plug into a proper outlet and turn the Power switch ON.
12. While pressing the trigger, slowly move the spraying tool back and forth over the soiled surface. Release the trigger to vacuum soiled water.
13. Continue to clean soiled area, working in small sections, until no more dirt can be removed.  
**Caution: Do not overwet.**
14. When the cleaning job is complete refer to the **Putting it Away** section for machine cleanup and storage instructions, page 14.

### Tip:

Deep cleaning carpeting and upholstery regularly can reduce dust and allergens in your home.

### Tip:

Try pre-treating stairs or entry ways with BISSELL Tough Stain PreCleaner.™ Then deep clean with the SmartMix® dial set on **High Traffic**.



# Cleaning bare floors

The Bare Floor Tool provides effective cleaning for linoleum, vinyl, and tile floors.

**Caution: Do not use on hardwood floors.**

1. Use only BISSELL Floor Cleansing Formula™.
2. Vacuum or sweep thoroughly to pick up loose debris and pet hair.
3. Remove easily moved furniture from the room, (chairs, tables, etc).
4. Plan your cleaning route to leave an exit path.
5. Plan activities to allow about 30 minutes for the floor to dry completely.

## Attach the Bare Floor Tool

6. Step on the handle release to lay the machine handle down.
7. Remove the Tank-in-Tank™ from the machine base.
8. Lift the machine base to expose the underside of the nozzle.
9. Attach Bare Floor Tool to nozzle with long tab to the right side (ReadyTools™ side) of the nozzle.
10. First attach left side (short tab) catching tab over nozzle edge.
11. Gently bend long tab (right side) outward to easily snap over edge of clear nozzle on left.

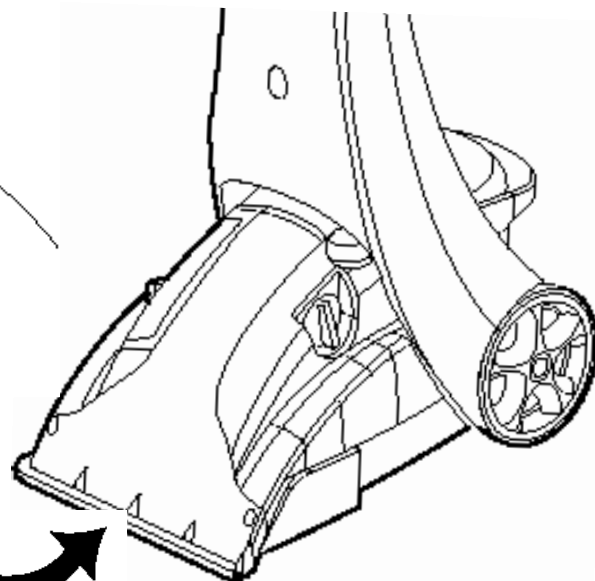
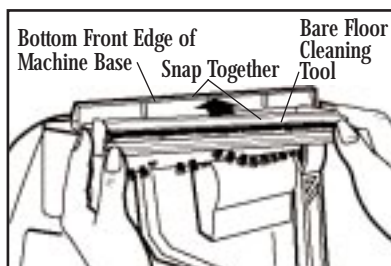
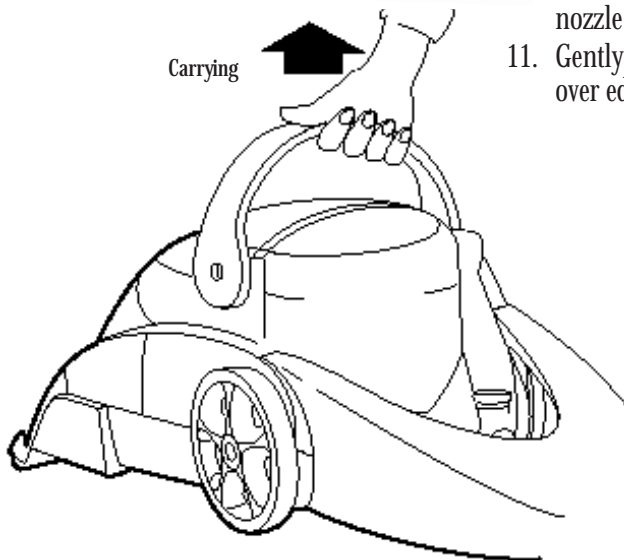
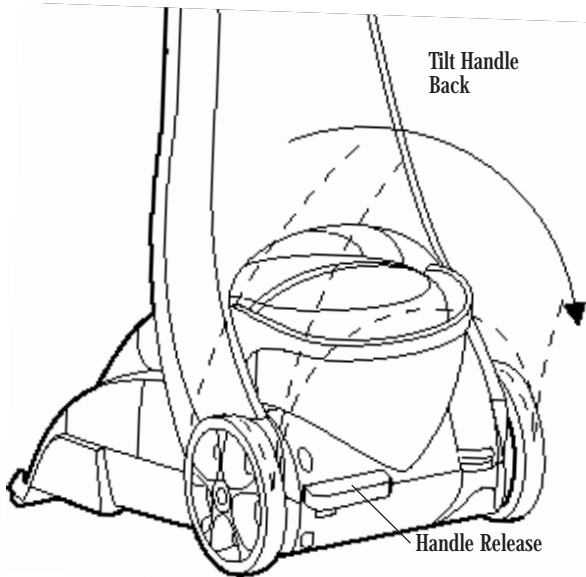

## Machine Preparation

12. Set up machine following instructions in **The Basics** section, pages 5-9. Be sure to thoroughly rinse out any remaining Fiber Cleansing Formula™ to prevent slippery linoleum, vinyl, and tile floors. **Use BISSELL Floor Cleansing Formula™ in the SmartMix® tank.**
13. Check ReadyTools™ switch - it should be set on Floor Cleaning.
14. Choose the SmartMix® setting to match the cleaning job.
15. Plug into a proper outlet and turn Power Switch ON. Turn SmartTemp™ switch to ON. The SmartTemp™ Ready Light illuminates when POWERSTEAMER® PROHEAT™ PLUS is ready to clean.

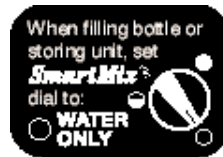

## Bare Floor Cleaning Technique

17. Slowly move the machine nozzle with Bare Floor Tool forward and back over soiled surface one time while pressing the trigger.  
**Caution: Do not over wet.**
18. Repeat the motion without pressing the trigger using the Bare Floor Tool to squeegee and suction up the dirty water.
19. Repeat steps 1 and 2 backing along the exit path.
20. Allow about 30 minutes for the floor to dry completely.
21. When the cleaning job is complete refer to the **Maintenance/Putting it Away** section, page 14, for machine cleanup and storage instructions.
22. To remove Bare Floor Tool gently bend long tab (right side) outward and pull tool down away from nozzle. Rinse thoroughly, dry and store.

**Keep plenty of genuine BISSELL Fiber Cleansing Formula™ on hand so you can clean whenever it fits your schedule. Always use genuine BISSELL deep cleaning formulas. Non-BISSELL cleaning solutions may harm the machine and void the warranty.**



## Maintenance/Putting it away

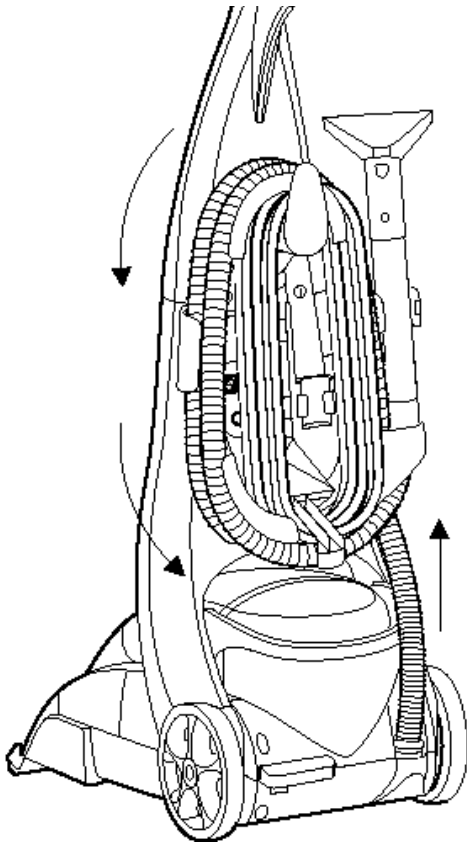

### Tip:

SmartMix®  
Bottle may be  
stored with  
concentrate  
ready for  
your next  
cleaning job.





**CAUTION:**  
POWERSTEAMER® PROHEAT™  
PLUS uses water and must  
not be stored where there  
is a danger of freezing.  
Freezing will damage  
internal components and  
void the warranty.

1. Turn Power and SmartTemp™ switches OFF.
2. Unplug power cord from the outlet and coil around machine cord wrap.

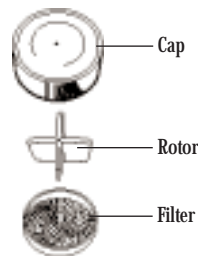

3. Remove and rinse tools in clean, running water, dry and replace in tool caddy.
4. Coil flex hose around storage brackets on tool caddy.
5. Remove Tank-in-Tank™, dispose of dirty water. See **The Basics** section, page 8.
6. Rinse out the Tank-in-Tank™ and replace on the machine.



7. Clean out the Flow Indicator Filter each time it is used to insure best cleaning performance. Unscrew the Flow Indicator Cap, lift out the red Rotor and white Filter. Rinse all three parts in tap water. Replace the Filter and Rotor. Replace the Flow Indicator Cap; turn until snug, do not over-tighten.
8. To remove the Clear Nozzle for cleaning out remaining dirt and carpet fibers, unscrew the two screws with a Phillips  screwdriver. Rotate the Clear Nozzle up toward the handle and lift out. Wipe machine base with a clean damp cloth. Rinse nozzle in tap water and replace. Catch the two tabs in the notches at the top, then rotate down and replace the screws.
9. Wipe all exterior surfaces with a soft cloth.
10. Store cleaner upright in a protected, dry area.

# Troubleshooting



**WARNING:**  
To reduce the risk of  
fire, electric shock or  
injury unplug from  
outlet before servicing.

## ***SmartTemp™ Ready Light does not illuminate.***

### **Possible Causes**

- The SmartTemp™ switch is not turned ON.
- The machine Power Switch is not turned ON.

### **Remedies**

- Turn On the SmartTemp™ switch.
- Both switches must be ON to activate the SmartTemp™ Ready Light.

## ***SmartTemp™ Power Switch does not illuminate.***

### **Possible Causes**

- The machine Power Switch is not turned ON.

### **Remedies**

- Turn On the SmartTemp™ switch.
- Both switches must be ON to activate the SmartTemp™ Ready Light.

## ***Reduced spray or no spray.***

### **Possible Causes**

- Bladder may be empty.
- SmartMix® Bottle may be empty.
- The filter may be clogged.
- Tanks may not be seated properly.
- Pump may have lost prime.
- The Pump Belt may be broken.

### **Remedies**

- Refill tank with hot tap water.
- Fill with Fiber Cleansing Formula.
- Clean out filter, page 14.
- Turn power OFF; remove and reseal tanks.
- Turn power OFF; after 1 minute turn ON and depress trigger.
- Turn the machine OFF and unplug from the outlet. To check if a Pump Belt has broken, you will need a flat head  screwdriver. Insert the blade end into the lower slot of the Belt Access door to release the lower snap. If necessary, insert the blade end into the upper slot to release the upper snap. Examine for belt breakage. You should be able to see the Pump Belt looped around the white pulley. If it is broken or missing, please refer to **Part Numbers and Descriptions** on page 17 before calling Consumer Services. Complete installation instructions will accompany the replacement belt.

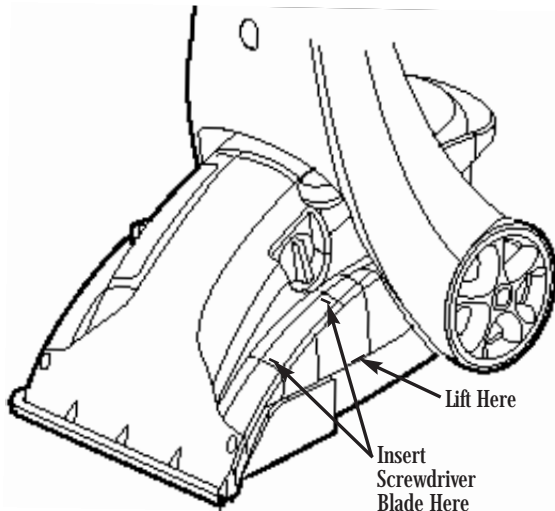

## Troubleshooting - continued

### ***Dirtlifter® PowerBrush® does not turn.***

#### **Possible Causes**

---

The Brush Belt or Pump Belt may be broken.

#### **Remedies**

---

Turn the machine OFF and unplug from the outlet. To check if a Brush Belt has broken, you will need a flat head  screwdriver. Insert the blade end into the lower slot of the Belt Access door to release the lower snap. If necessary, insert the blade end into the upper slot to release the upper snap. Examine for belt breakage. The Brush Belt should be visible, looped around the motor shaft. If it is broken or missing, please refer to **Part Numbers and Descriptions** on page 17 before calling Consumer Services. Complete installation instructions will accompany the replacement belt.

### ***Vacuum not picking up solution.***

#### **Possible Causes**

---

ReadyTools™ switch may be at the wrong setting for the cleaning job.

Drain cap may be missing or not properly installed at back of Tank-in-Tank™.

Tank-in-Tank™ lid is not properly installed.

Tank-in-Tank™ is not properly seated.

Poor tool position.  
(Hand held attachments only).

Tank-in-Tank™ has picked up maximum dirty water.

#### **Remedies**

---

Set ReadyTools™ switch to either Tools or PreTreat or Floor Cleaning.

Remove Tank-in-Tank™, loosen and re-tighten Drain Cap.

Re-install lid; refer to **The Basics** section.

Tank-in-Tank™ must be firmly seated to function; remove and reseat Tank-in-Tank™.

Adjust angle; apply more downward pressure.

Empty Tank-in-Tank™, refer to **The Basics** section.

# Part numbers and descriptions\*

\*Not all parts included with every model.

Item	Part No.	Part Name
------	----------	-----------

1	010-9201	4" Small Area Tool
2	603-0910	6" Stair Tool
3	010-9148	Spraying Crevice Tool
4	010-1185	TurboBrush™
5	014-9131	Bare Floor Tool
6	014-9142	PreTreat Wand
7	015-9155	Tough Stain Brush
8	013-0212	Baffle
9	014-0325	Red Float
10	015-9040	Tank Assembly
11	010-6241	Tank Seal
12	014-2987	Tank Lid Assembly
13	013-4435	Tank Handle
14	014-1782	Tank Drain Cap
15	010-1785	SmartMix® Bottle (Includes Cap)
16	010-1795	SmartMix® Cap Assembly
17	010-1651	Flow Indicator Cap
18	010-6214	Flow Indicator O-Ring
19	010-7635	Flow Indicator Rotor
20	010-3510	Flow Indicator Filter
21	014-9860	Floor Nozzle Window and Gasket
22	010-4052	Window Gasket
23	010-0620	Belt – Pump
24	010-0621	Belt – Brush

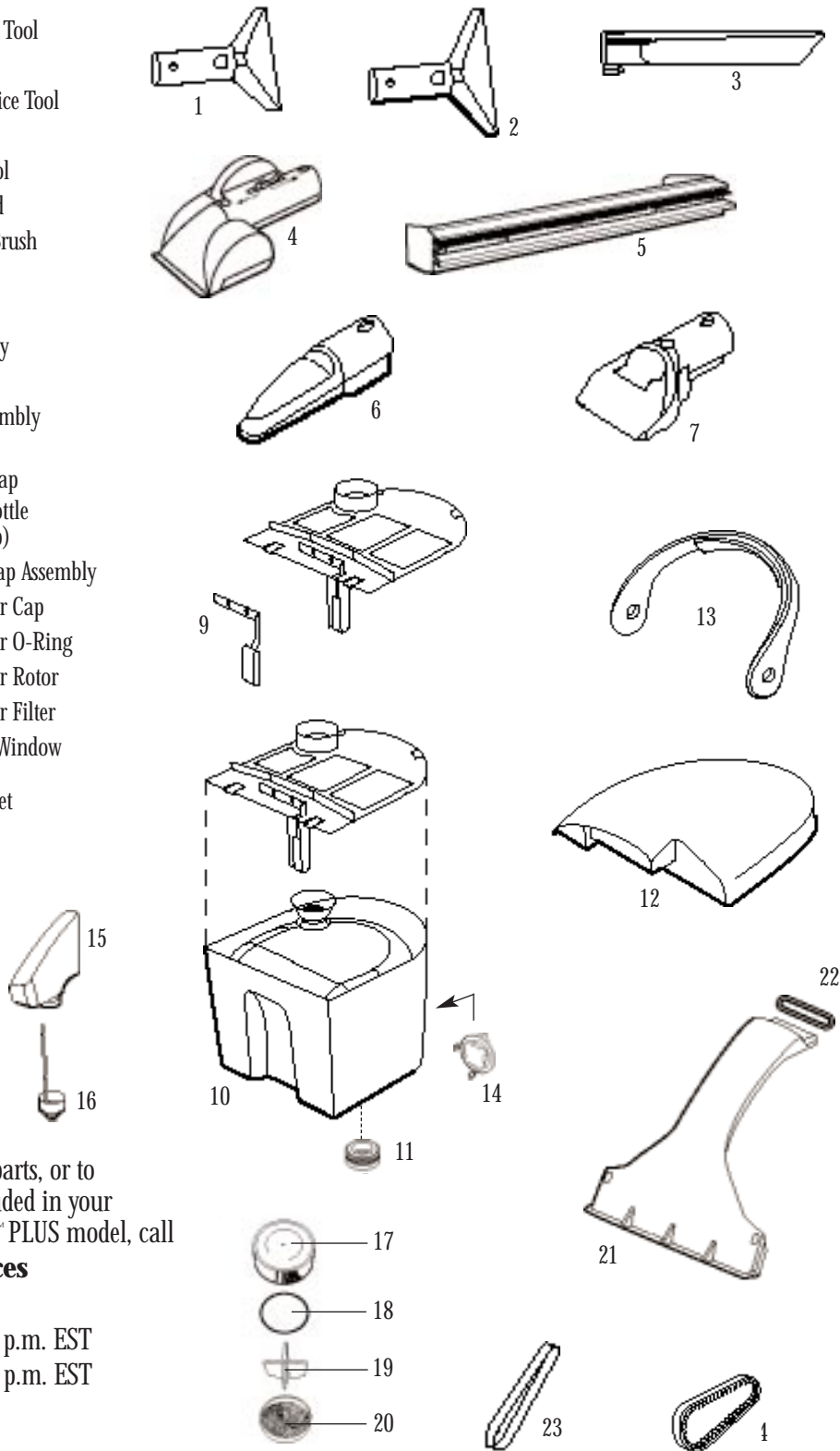

NOTE: To order replacement parts, or to order parts not originally included in your POWERSTEAMER® PROHEAT™ PLUS model, call

**BISSELL Consumer Services**

**1-800-237-7691**

Monday - Friday 8 a.m. — 7 p.m. EST

Saturday 9 a.m. — 2 p.m. EST

## About your warranty

This warranty gives you specific legal rights, and you may also have other rights which may vary from state to state. If you need additional instruction regarding this warranty or have questions regarding what it may cover, call BISSELL Consumer Services.



**WARNING:** Use only BISSELL Fiber Cleansing Formula™ or BISSELL Floor Cleansing Formula™ in your POWERSTEAMER® PROHEAT™ PLUS. Use of cleaning formulas which contain lemon or pine oil may damage this appliance and void warranty. Chemical spot cleaners or solvent-based soil removers should not be used. These products may react with the plastic materials used in your POWERSTEAMER® PROHEAT™ PLUS causing cracking or pitting.

### One Year Warranty

BISSELL Inc., upon receipt of the product, will repair or replace, free of charge, any part which is defective or malfunctioning within one year of the purchase date, provided that it is used for personal and not commercial or rental service. If the deep cleaner cannot be repaired, BISSELL Inc. will replace or refund the full price, at your option.

### If your BISSELL product should require service

1. Call BISSELL Consumer Services at 1-800-237-7691 and we will give you the name and address of an authorized BISSELL Service Center in your area.
2. If there is not an authorized BISSELL Service Center in your area, a BISSELL Consumer Services Representative will assist you with servicing your unit.

You can also visit the BISSELL website - <http://www.bissell.com> to locate a Service Center near you.

## BISSELL Consumer Services

For information about repairs or replacement parts, or questions about your warranty, call:

**BISSELL Consumer Services**

**1-800-237-7691**

Monday - Friday 8 a.m. — 7 p.m. EST

Saturday 9 a.m. — 2 p.m. EST

Visit our web site at <http://www.bissell.com>

Or write:

**BISSELL INC**

**PO Box 3606**

**Grand Rapids MI 49501**

**ATTN: Consumer Services**

When contacting BISSELL, have model number of unit available.

Please record your Model Number: \_\_\_\_\_

Please record your Purchase Date: \_\_\_\_\_

**NOTE: Please keep your original sales receipt. It is your warranty.**

**“ASK ANNA”**

**Product Information**

**Purchase Products & Parts**

**<http://www.bissell.com>**



©1998 BISSELL Inc  
Grand Rapids, Michigan  
All rights reserved.  
Part Number 010-5710  
Rev 11/98